

betzer[®]**b**
Precision fasteners · Cold forming technology



REMFORM[®]

**Thread-forming Fasteners
for Plastics and Light Alloys**

betzer **b**[®]
Precision fasteners · Cold forming technology



REMFORM[®]

Thread-forming Fasteners for Plastics and Light Alloys

REMFORM[®] fasteners help lower the cost of assembly in engineered plastic materials. By eliminating weight while providing the requisite fastening performance, REMFORM[®] fasteners create value for designers, manufacturers and end users.

REMFORM[®] fasteners combine a thread form that promotes efficient material flow during thread-forming while also creating exceptional resistance to pullout forces. REMFORM[®] fasteners' ability to create high quality internal threads while minimizing the risk of boss bursting in the assembly process makes them an excellent thread-forming fastener.

Users who standardize on **REMFORM[®]** fasteners for plastic and light alloy material applications find efficiencies in:

- Research and Development
- Fastener acquisition
- Logistics
- Manufacturing
- After-market sales and service

REMFORM[®] fasteners are used to assemble a broad range of products across a multitude of industries globally.

REMFORM[®] fasteners can be found in products including but not limited to cars, toys, furniture, cell phones, fitness equipment, printers, photocopiers, hedge trimmers and countless other products.

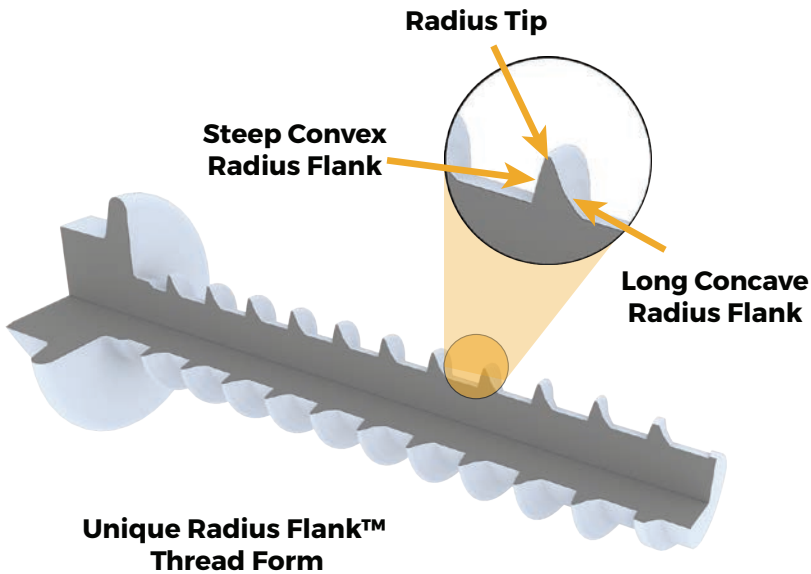

As designers attempt to reduce weight and improve the strength of products, engineered plastics become an increasingly prevalent material choice. **REMFORM® II™** fasteners are the solution for joining these materials.

The **REMFORM® II™** screw is a thread-forming fastener with a unique thread form to provide superior performance in a wide range of engineered plastics. The asymmetrical thread minimizes radial hoop stress to reduce boss bursting. The narrow tip angle also reduces stress in the plastic nut member.

Reduced Hoop Stress

The radial tip thread crest of **REMFORM® II™** screws reduces sharp corners, which reduces radial hoop stress in the plastic caused by thread-forming. When a threaded fastener is tightened, nearly all of the axial tightening load is opposed by the trailing or pressure flank of the screw and the mating thread flank of the internal thread. The steep pressure flank transfers most of the resultant tightening load in the axial direction, minimizing boss bursting tendencies created by the radial force. The axial force is over 4.5 times greater than the radial force.

The Unique Radius Flank™ Thread Form

REMFORM® II™ screws employ the **Unique Radius Flank™** asymmetrical thread form shown in the drawing to the left. The leading thread flank is most influential in forming the mating thread. The intercepting radius form on the leading flank is there to promote efficient material displacement and material flow. The pressure flank which opposes the fastener head is engineered to resist pull-out forces, whether they be applied by a tensile load or induced by torque. The steep pressure flank has a subtle radius designed to increase resistance to pullout and to efficiently develop tension. It also provides excellent material contact resulting in a high resistance to the internal threads stripping. In applications where the failure mode is fastener fracture, the high torsional strength of **REMFORM® II™** fasteners ensures a high failure torque and improved resistance to loosening. This unique thread form and its narrow tip angle efficiently displace material and therefore require minimal energy to form an internal thread. The tip also utilizes a radius to better create the internal thread without increasing hoop stress in the plastic.

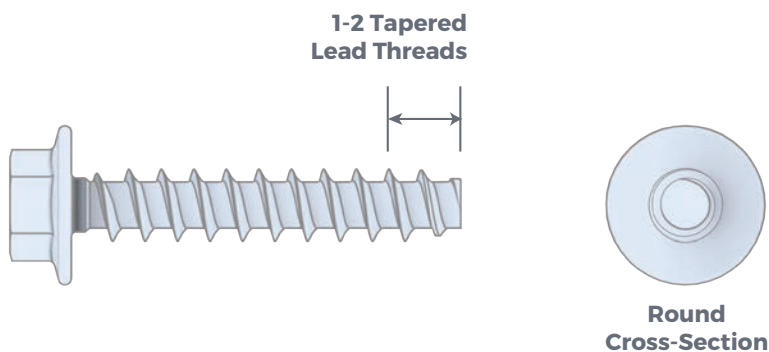

 **REMFORM[®] II HS[™]**

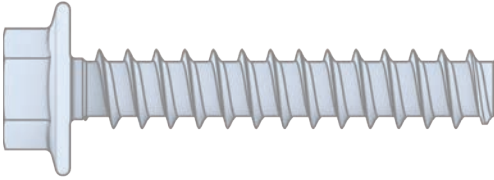

REMFORM[®] II HS[™] fasteners were developed to combine the features of REMFORM[®] II[™] and REMFORM[®] II F[™] fasteners with an optimized gap between the threads and core diameter. These optimizations allow a better flow of the mating plastic material and accept a higher amount of material between the flanks. This reduces overstressing of the plastic material during the assembly process.

The optimized core diameter provides a higher torsional strength, advantageous when the fastener is used in higher strength or fiber-reinforced materials. In applications with higher axial thread engagement, the optimized pitch allows more threads to be in contact with the plastic material.

The REMFORM[®] II HS[™] fastener also uses the Unique Radius Flank[™] asymmetrical thread design which is the standard for all REMFORM[®] fasteners.

 **REMFORM[®] II F[™]**

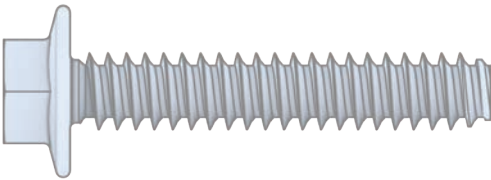

The **REMFORM[®] II F[™]** screw employs a finer pitch spacing to the efficient thread form of the standard REMFORM[®] II[™] fastener, ideal for magnesium, soft aluminum, and other low ductility materials. The narrow tip angle minimizes the disturbance of a low ductility nut member.

 **REMFORM[®]**

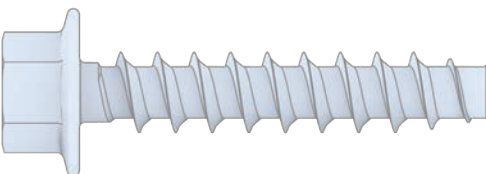

The original **REMFORM[®]** screw first featured the unique asymmetrical thread profile that minimizes radial hoop stress to reduce boss bursting. The narrow tip angle also reduces stress in the plastic nut member.

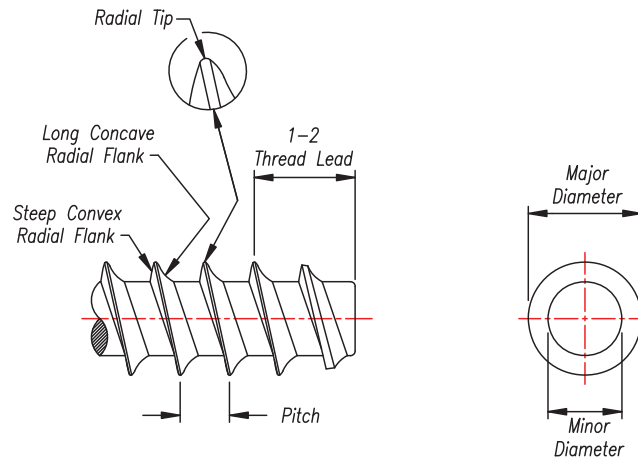
Metric Series

SIZE	PITCH	MAJOR DIA.		MINOR DIA.
		mm	mm	Max.
1.0	0.55	1.07	1.00	0.64
1.2	0.65	1.27	1.20	0.77
1.4	0.75	1.47	1.40	0.89
1.6	0.85	1.70	1.60	1.02
1.8	0.85	1.90	1.80	1.15
2.0	1.00	2.10	2.00	1.17
2.2	1.05	2.30	2.20	1.29
2.5	1.15	2.60	2.50	1.48
3.0	1.35	3.10	3.00	1.90
3.5	1.55	3.60	3.50	2.22
4.0	1.75	4.10	4.00	2.55
4.5	2.00	4.60	4.50	2.87
5.0	2.25	5.15	5.00	3.19
6.0	2.65	6.15	6.00	3.84
7.0	3.10	7.15	7.00	4.48
8.0	3.50	8.15	8.00	5.11
9.0	4.00	9.15	9.00	5.74
10.0	4.50	10.15	10.00	6.37



RECOMMENDED HOLE SIZES

MATERIAL TYPE	H HOLE DIA. Factor X Min. Screw Dia.
PP	0.75
PE	0.75
PA (Nylon 6 / 6.6)	0.75
ABS / PC Blend	0.75
ASA	0.75
ABS	0.75
PVC (rigid)	0.80
SAN	0.80
PS	0.80
PBT	0.80
PET	0.80
PC	0.80
PPO	0.80
PET 30% GF	0.80
PC 30% GF	0.82
PPO 30% GF	0.82
PA 6 30%GF	0.85
PBT 30% GF	0.85

SUGGESTED BOSS CONFIGURATION

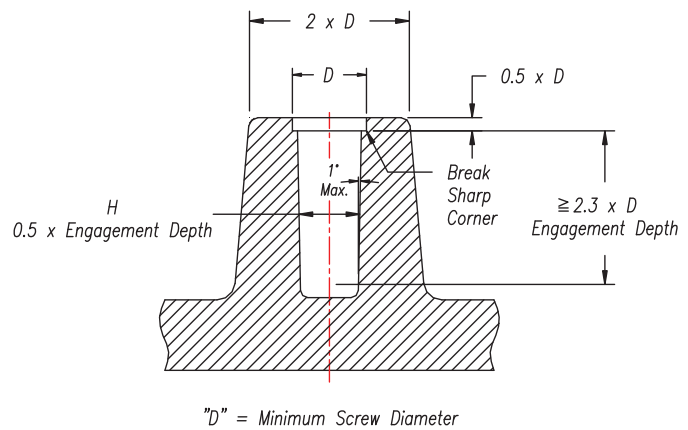

Hole sizes for the plastics listed in the table are derived by multiplying the minimum screw diameter by the factor listed in the table. The resulting hole size should be considered as a starting point which may need to be adjusted due to specific application conditions.

Reduced Hoop Stress

The radial tip thread crest of REMFORM[®] II[™] screws reduces sharp corners, which reduces radial hoop stress in the plastic caused by thread forming.

When a threaded fastener is tightened, nearly all of the axial tightening load, designated **F**, is opposed by the trailing or pressure flank of the screw and the mating thread flank of the internal thread. The steep pressure flank transfers most of the resultant tightening load in the axial direction, **F_a**, minimizing boss bursting tendencies created by the radial force, **F_r**. The axial force, **F_a**, is over 4.5 times greater than **F_r**, the radial force.

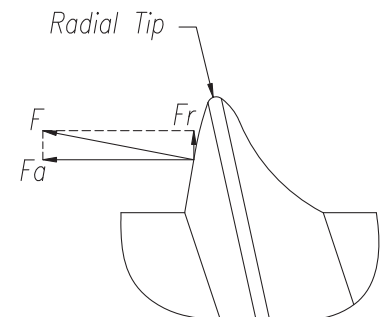

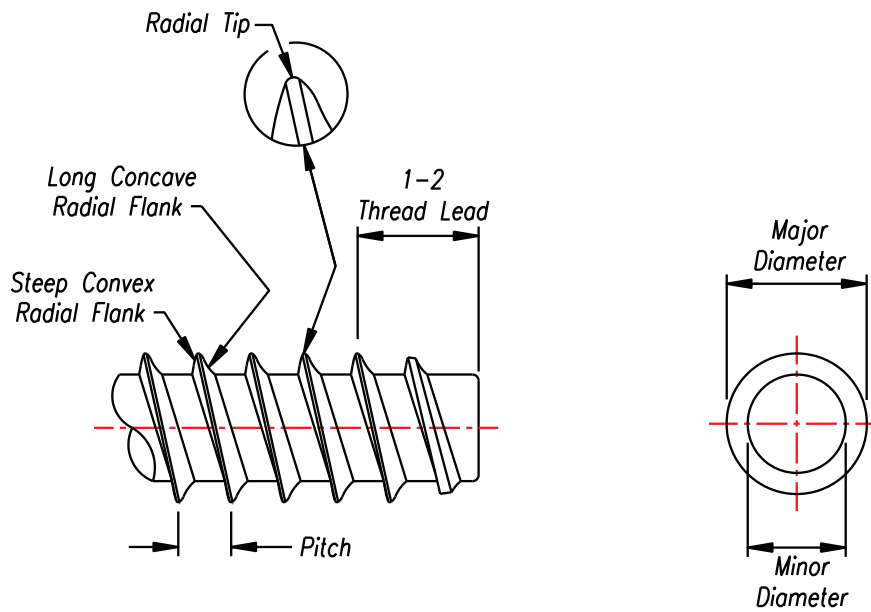
REMFORM[®] II HS[™]

Metric Series

SIZE	PITCH	MAJOR DIA.		MINOR DIA.
		Max.	Min.	
2.0	0.78	2.08	2.00	1.28
2.2	0.85	2.28	2.20	1.43
2.5	0.95	2.60	2.50	1.64
3.0	1.12	3.10	3.00	2.01
3.5	1.29	3.60	3.50	2.37
4.0	1.46	4.10	4.00	2.73
4.5	1.63	4.60	4.50	3.09
5.0	1.80	5.15	5.00	3.43
6.0	2.14	6.15	6.00	4.16
7.0	2.48	7.18	7.00	4.86
8.0	2.82	8.18	8.00	5.58
9.0	3.16	9.25	9.00	6.28
10.0	3.50	10.25	10.00	7.00

Dimensions in mm

Note: Sizes 1.0 - 1.8 available upon request

REMFORM[®] II HS[™]

RECOMMENDED HOLE SIZES

MATERIAL TYPE	H HOLE DIA. Factor X Min. Screw Dia.
PP	0.75
PE	0.75
PA (Nylon 6 / 6.6)	0.75
ABS / PC Blend	0.75
ASA	0.75
ABS	0.75
PVC (rigid)	0.80
SAN	0.80
PS	0.80
PBT	0.80
PET	0.80
PC	0.80
PPO	0.80
PET 30% GF	0.80
PC 30% GF	0.82
PPO 30% GF	0.82
PA 6 30%GF	0.85
PBT 30% GF	0.85

SUGGESTED BOSS CONFIGURATION

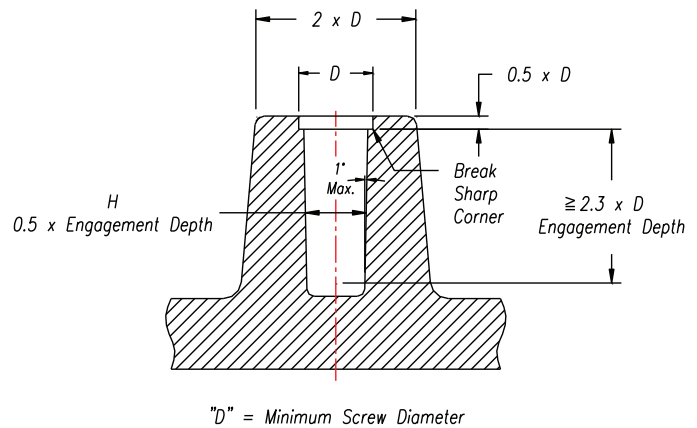

Hole sizes for the plastics listed in the table are derived by multiplying the minimum screw diameter by the factor listed in the table. The resulting hole size should be considered as a starting point which may need to be adjusted due to specific application conditions.

Reduced Hoop Stress

The radial tip thread crest of REMFORM[®] II[™] "HS" screws reduces sharp corners, which reduces radial hoop stress in the plastic caused by thread forming.

When a threaded fastener is tightened, nearly all of the axial tightening load, designated **F**, is opposed by the trailing or pressure flank of the screw and the mating thread flank of the internal thread. The steep pressure flank transfers most of the resultant tightening load in the axial direction, **F_a**, minimizing boss bursting tendencies created by the radial force, **F_r**. The axial force, **F_a**, is over 4.5 times greater than **F_r**, the radial force.

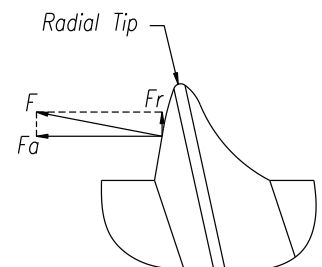

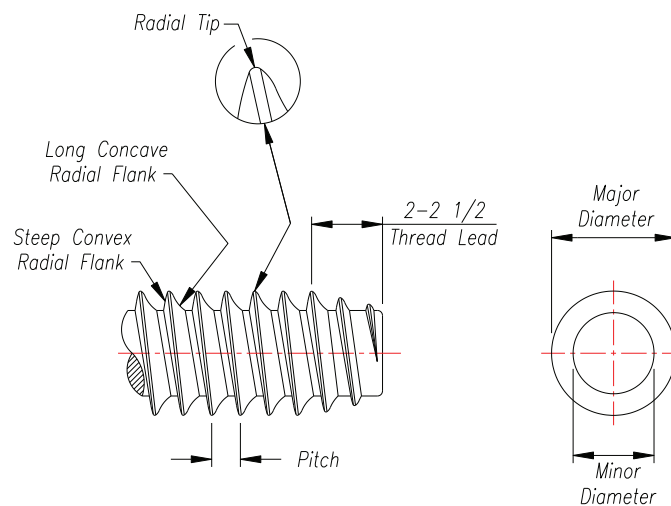

REMFORM[®] II F[™]

Metric Series

SIZE mm	PITCH mm	MAJOR DIA.		MINOR DIA.
		Max.	Min.	Min.
1.0	0.30	1.07	1.00	0.68
1.2	0.40	1.27	1.20	0.81
1.4	0.45	1.47	1.40	0.95
1.6	0.50	1.70	1.60	1.08
1.8	0.55	1.90	1.80	1.22
2.0	0.60	2.10	2.00	1.33
2.2	0.70	2.30	2.20	1.47
2.5	0.70	2.60	2.50	1.68
3.0	0.80	3.10	3.00	2.02
3.5	0.95	3.60	3.50	2.37
4.0	1.05	4.10	4.00	2.71
5.0	1.25	5.15	5.00	3.40
6.0	1.40	6.15	6.00	4.09
7.0	1.55	7.15	7.00	4.78
8.0	1.75	8.15	8.00	5.46
10.0	2.25	10.15	10.00	6.82

Dimensions in mm

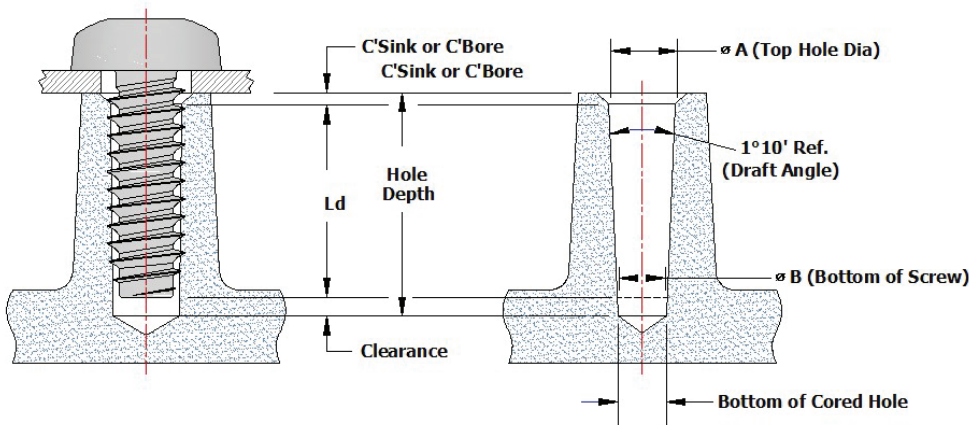
REMFORM[®] II F[™]

CAST CORED HOLE



DRILLED HOLE

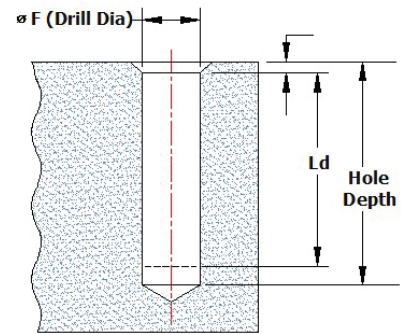

Screw Size	Cored Hole Diameters				F Drilled Hole Diameter		Ld Recommended Length Of Thread Engagement
	ØA - Top of Cored Hole	ØB - Bottom of Screw Engagement	Max.	Min.	Max.	Min.	
1.00 - 0.30	0.95	0.91	0.90	0.86	0.93	0.89	2.50
1.20 - 0.40	1.14	1.09	1.07	1.02	1.10	1.05	3.00
1.40 - 0.45	1.32	1.26	1.25	1.19	1.28	1.22	3.50
1.60 - 0.50	1.52	1.45	1.44	1.37	1.47	1.40	4.00
1.80 - 0.55	1.70	1.63	1.60	1.53	1.64	1.57	4.50
2.00 - 0.60	1.87	1.79	1.77	1.69	1.82	1.74	5.00
2.20 - 0.70	2.04	1.96	1.93	1.85	1.99	1.91	5.50
2.50 - 0.70	2.32	2.24	2.19	2.11	2.26	2.18	6.25
3.00 - 0.80	2.78	2.70	2.62	2.54	2.70	2.62	7.50
3.50 - 0.95	3.22	3.14	3.04	2.96	3.13	3.05	8.75
4.00 - 1.05	3.68	3.60	3.47	3.39	3.57	3.49	10.00
5.00 - 1.25	4.61	4.53	4.36	4.28	4.49	4.41	12.50
6.00 - 1.40	5.53	5.45	5.22	5.14	5.38	5.30	15.00
7.00 - 1.55	6.46	6.38	6.10	6.02	6.28	6.20	17.50
8.00 - 1.75	7.36	7.28	6.95	6.87	7.16	7.08	20.00
10.00 - 2.25	9.17	9.09	8.66	8.58	8.91	8.83	25.00



Precision fasteners · Cold forming technology

Schrauben Betzer GmbH & Co. KG
Postfach 1243
D-58462 Lüdenscheid

Heedfelder Straße 61-63
D-58509 Lüdenscheid

Telefon: +49-(0)2351-9692-0
Telefax: +49-(0)2351-9692-96

mail@betzer.de · www.betzer.de

